



# NIGHT-LITE PRO II®

V-SERIES®

The **Night-Lite Pro II® V-Series®** offers four different engine models and features a vertical tower with power cables encased in Nycoil™ flexible tubing to eliminate tangling and stretching of the tower wiring. The SHO-HD® lamp fixtures provide 110,000 to 135,500 lumens per lamp – more than competitive light towers. With a 114 liter (30 gallon) polyethylene fuel tank, this dependable light tower will keep your jobsite running all through the night.



A SUBSIDIARY OF



BRIGGS & STRATTON  
CORPORATION

# KEY FEATURES

## Night-Lite Pro II® V-Series®

**(4) Metal Halide Light Fixtures**

**359° Fixture Rotation**

**89 kph Operating Wind Speed Rating**

**Galvanized Towers**

**Guide Pads**  
Polyethylene self-lubricating

**Actuation Hydraulic Mast**

**Gull-Wing-Style Doors**  
Reaction Injection Molded (RIM) doors provide strength and corrosion resistance with a lockable latch

**Frame** Formed, welded steel frame

**Axle** Tubular axle with elliptical leaf springs

**Removable Tongue**

**Reversible Coupler**  
2" ball / 3" pintle

**Remote Engine Oil Drain** Easily accessible at rear of trailer

**114 Liter Polyethylene Fuel Tank**

**Height\***  
Mast Lowered MH / LED / Balloon  
8.3 ft (2.5 m) /  
7.9 ft (2.4 m) /  
7.9 ft (2.4 m)

Mast Raised MH / LED / Balloon  
26.7 ft (8.1 m) /  
26.2 ft (8.0 m) /  
29.8 ft (9.1 m)

### Width

Transport / Operating  
50.5 in (1,283 mm) /  
100.6 in (2,555 mm)

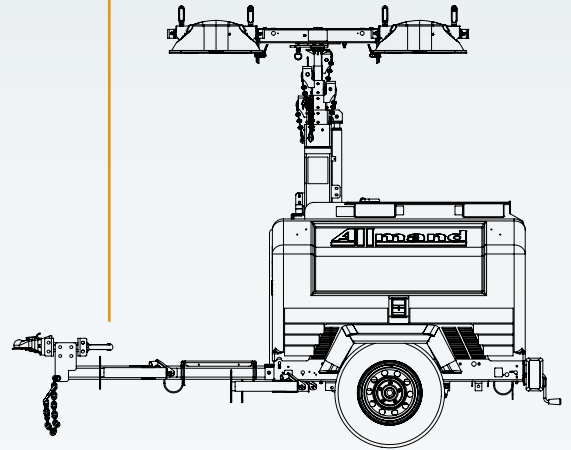

### Length

Transport / Operating  
119.8 in (3,043 mm) /  
119.8 in (3,043 mm)

**Structure** Six-section tubular steel design

### Sequenced Light System (SLS™)

Automatically delays engine shutdown to turn off lights and prevent generator from shutting down while under load.

### Fluid Containment System (FCS)

Holds up to 110% of all on-board fluids

### Trailer Lighting

Stop, turn, tail lights / side marker lights / illuminated license plate bracket

### Hour Meter

### Lifting Eye

**Tires** ST175 / 80R13 load range 'C'

**Stabilizers** Four-point design, tongue jack, (2) retractable side outriggers at front of trailer, rear jack

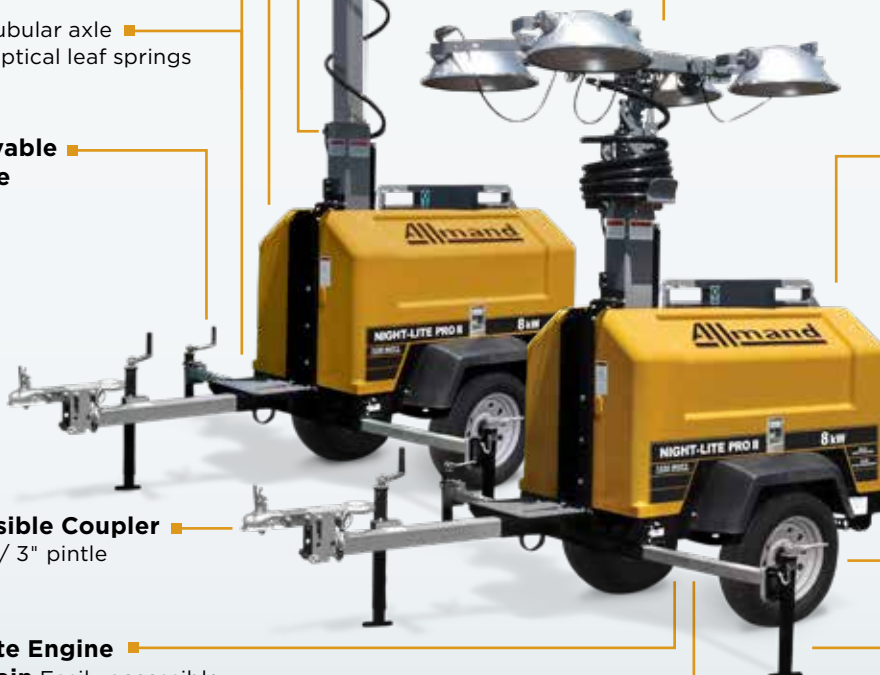

Model	50 Hz NLPROV-KD1005	50 Hz NLPROV-CAT11	60 Hz NLPROV-KD1005	60 Hz NLPROV-CAT11
Engine Brand / Model	Kubota / D1005	CAT / 1.1	Kubota / D1005	CAT / 1.1
Engine Prime Power (kW)**	6	6	7	8
Fuel Capacity gal (L)	30 (113.6)	30 (113.6)	30 (113.6)	30 (113.6)
Light Type - Metal Halide	(4) Metal Halide SHO-HD® fixture			
Metal Halide Wattage (per lamp)	1,000	1,000	1,250	1,250
Metal Halide Lumens (per lamp / total)	110,000 / 440,000	110,000 / 440,000	135,500 / 542,000	135,500 / 542,000
Operating Time (hrs)*** <small>(Using four 1,250-W metal halide light fixtures)</small>	N/A	N/A	48.4	50
Operating Time (hrs)*** <small>(Using four 1,000-W metal halide light fixtures)</small>	63.8	65.2	N/A	N/A
Light Type - LED (Optional)	(4) Two LED, 5,000°K color temperature			
LED Wattage (per lamp)	320	320	320	320
LED Lumens (per lamp / total)	38,500 / 154,000	38,500 / 154,000	38,500 / 154,000	38,500 / 154,000
Operating Time (hrs)*** <small>(Using four 320-W LED light fixtures)</small>	97.4	100.0	103.4	78.9
<b>Features</b>				
Outlets	(2) Schuko Outlets	(2) Schuko Outlets	(1) GFCI Duplex Outlet (2) 30A 4-prong Twistlock	(1) GFCI Duplex Outlet (1) 30A 4-prong Twistlock (1) 30A RV
<b>Weights and Shipping</b>				
Weight lbs (kg)	1,950 (884.5)	1,950 (884.5)	1,950 (884.5)	1,950 (884.5)
Gross Vehicle Weight Rating (GVWR) lbs (kg)	2,200 (998)	2,200 (998)	2,200 (998)	2,200 (998)
Shipping	10 units on a 20' ocean container / 20 units on a 40' ocean container			
	16 units on a 48' or 53' flatbed			

LIGHT COVERAGE

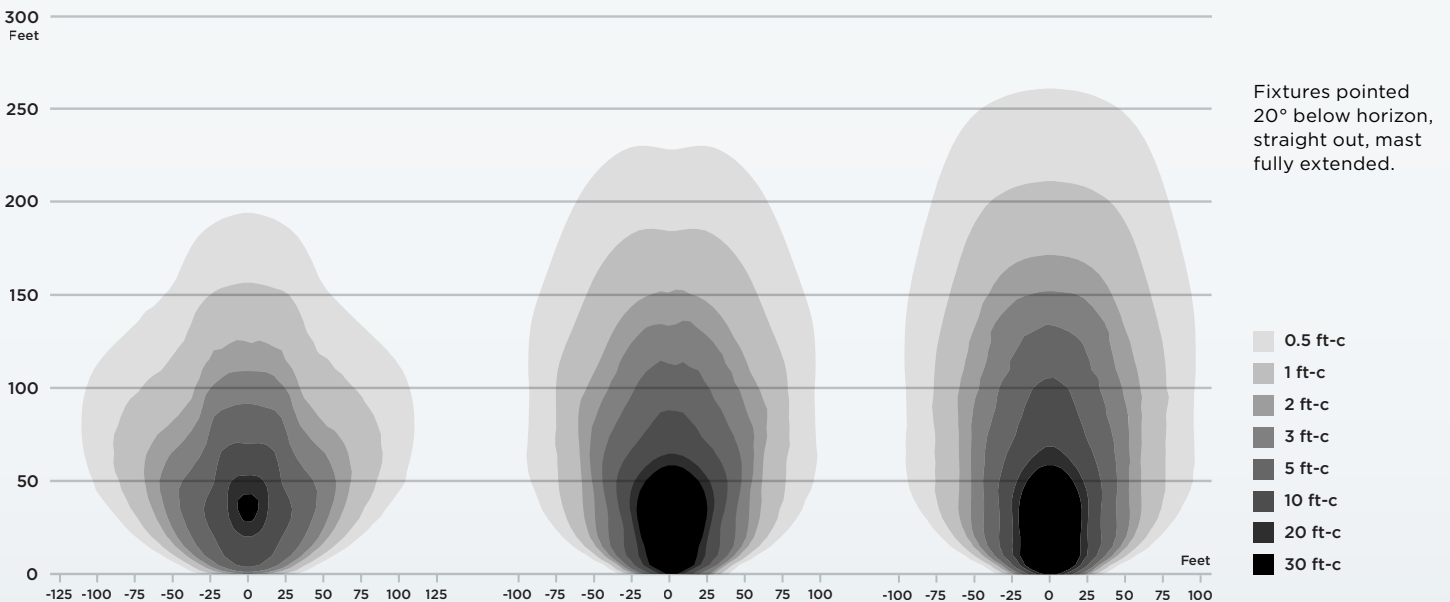

**Night-Lite Pro II® V-Series®**  
with four 320-W  
LED Light Output

Area lit to 0.5-foot candle or higher: 30,375 ft<sup>2</sup> (ft-c)

**Night-Lite Pro II® V-Series®**  
with four 1,000-W  
Metal Halide Light Output

Area lit to 0.5-foot candle or higher: 40,860 ft<sup>2</sup> (ft-c)

**Night-Lite™ V-Series®**  
with four 1,250-W  
Metal Halide Light Output

Area Lit to .5 Foot Candle (ft-c) or Higher: 42,597 ft<sup>2</sup>

\*Balloon light only included in raised dimension — balloon light is removed for transportation. \*\*Prime generator electrical output per Allmand® testing. \*\*\*Based on fuel consumption at 2,300' altitude per Allmand® testing. Allmand® has a policy of continuous product improvement and reserves the right to modify its specifications at any time and without prior notice. See operator's manual or Allmand.com for complete warranty details.

## OPTIONS

### Night-Lite Pro II® V-Series®



#### Balloon Light (60 Hz)

- Balloon Light features the AirStar Flex diffused lighting system using Allmand's exclusive bulbs. This system provides reduced glare while still illuminating a large area.



#### LED Package

- (4) LED light fixtures



#### LSC with E-Stop Package

(Not available with Mitsubishi engine)

- LSC 2.1™ - Light Sequence Commander® automatically starts engine at sunset and shuts down engine at sunrise - programmable for user preferences.
- Emergency stop switch on exterior of machine

#### Telematics Package

(Customer supplied - consult factory)

#### Lockable Battery Disconnect

#### Skid Mount

#### Custom Paint



## COMPROMISE NOTHING.

At Allmand, our sole focus is providing jobsite support equipment to help your customers get the job done. Whenever they need it. Wherever they are. And whatever it takes. What's more, our genuine commitment to you — the highest standard of service and lowest total cost of ownership — is simply unmatched. Choose the equipment that comes with complete confidence that jobsite productivity won't go dark at 2 a.m. **Allmand. Above All.**