

STANDARD EQUIPMENT

ISO Standard cabin
All-weather steel cab with 360° visibility
Safety glass windows
Rise-up type windshield wiper
Sliding fold-in front window
Sliding side window(LH)
Lockable door
Hot & cool box
Storage compartment & Ashtray
Transparent cabin roof-cover
CD/MP3 Player
Handsfree mobile phone system with USB
Sun visor
12 volt power outlet (24V DC to 12V DC converter)
Computer aided power optimization (New CAPO) system
3-power mode, 2-work mode, User mode
Auto deceleration & one-touch deceleration system
Auto warm-up system
Auto overheat prevention system
Automatic climate control
Air conditioner & heater
Defroster
Self-diagnostics system
Starting Aid (air grid heater) for cold weather
Centralized monitoring
LCD display
Engine speed or Trip meter/Accel.
Clock
Gauges
Fuel level gauge
Engine coolant temperature gauge
Hyd. oil temperature gauge
Warnings
Check Engine
Communication error
Low battery
Air cleaner clogging
Indicators
Power max
Fuel warmer
Auto idle
Door and cab locks, one key
Two outside rearview mirrors
Mechanical suspension seat with heater
Pilot-operated slidable joystick
Console box height adjust system
Four front working lights
Electric horn
Batteries (2 x 12V x 80 AH)
Battery master switch
Removable clean-out screen for oil cooler
Automatic swing brake
Removable reservoir tank
Fuel pre-filter with fuel warmer
Boom holding system
Arm holding system
Counterweight (2,800kg, 6,170lb)
Track shoes (500mm, 20")
Track rail guard
Accumulator for lowering work equipment
Electric transducer
Lower frame under cover (Normal)

OPTIONAL EQUIPMENT

Fuel filler pump (35 L/min)
Beacon lamp
Safety lock valve for boom cylinder with overload warning device
Safety lock valve for arm cylinder
Single-acting piping kit (breaker, etc.)
Double-acting piping kit (clamshell, etc.)
Quick coupler
Travel alarm
Arms
Super Short arm (1.9 m, 6' 3")
Short arm (2.1 m, 6' 11")
Long arm (3.0 m, 9' 10")
Cabin lights
Cabin front window rain guard
Track shoes
Triple grousers shoe (600mm, 24")
Triple grousers shoe (700mm, 28")
Lower frame under cover (Additional)
Long crawler lower frame
Dozer blade
Tool kit
Operator suit
Rearview camera
Pattern change valve (2 patterns)
Hi-mate (Remote Management System)

- * Standard and optional equipment may vary. Contact your Hyundai dealer for more information. The machine may vary according to International standards.
- * The photos may include attachments and optional equipment that are not available in your area.
- * Materials and specifications are subject to change without advance notice.
- * All imperial measurements rounded off to the nearest pound or inch.

PLEASE CONTACT

HYUNDAI

HEAVY INDUSTRIES CO.,LTD.

CONSTRUCTION EQUIPMENT

Head Office (Sales Office)
1 JEONHA-DONG, DONG-GU, ULSAN, KOREA TEL: (82) 52-202-7970, 7729, 0971 FAX: (82) 52-202-7979, 7720

U.S. Operation: Hyundai Construction Equipment Americas, Inc.
955 ESTES AVENUE, ELK GROVE VILLAGE, IL. 60007, U.S.A. TEL: (1) 847-437-3333 FAX: (1) 847-437-3574

European Operation: Hyundai Heavy Industries Europe N.V.
VOSSENDAAL 11, 2440 GEEL, BELGIUM TEL: (32) 14-56-2200 FAX: (32) 14-59-3405

India Operation: Hyundai Construction Equipment India Pvt., Ltd.
PLOT NO.A-2, CHAKAN INDUSTRIAL AREA, VILL.- KHALUMBRE. TALUK.- KHED., DIST.- PUNE 410 501, INDIA
TEL: (91) 21-3530-1700 FAX: (91) 21-3530-1712

We build a better future

Robex

145CR-9

With Tier 3 Engine installed



*Photo may include optional equipment.

Pride at Work

Hyundai Heavy Industries strives to build state-of-the-art earthmoving equipment to give every operator maximum performance, more precision, versatile machine preferences, and proven quality. Take pride in your work with Hyundai!

Robex 145CR-9

Machine Walk-Around

Undercarriage

Sealed track chain (urethane seals) / Standard track rail guard / Comfortable bolt-on steps
Large upper roller cut-outs for debris clean-out / Tapered side frames for debris clean-out / Grease-type track tensioner

Engine Technology

Proven / reliable, fuel efficient Mitsubishi Tier III D04FD-TAA engine
Electronically controlled for optimum fuel to air ratio and clean, efficient combustion
Low noise / Auto engine overheat feature / Anti-restart feature

Hydraulic System Improvements

New patented hydraulic control for improved controllability / Improved control valve design for added efficiency and smoother operation / New auto boom and swing priority system for optimum speed / New auto power boost feature for additional power when needed / Improved arm-in and boom-down flow regeneration system for added speed and efficiency

Pump Compartment

Industry-leading, powerful, reliable Kawasaki designed, variable volume in-line axial piston pumps
New compact solenoid block equipped with 3 solenoid valves, 1 EPPR valve, 1 check valve accumulator and line filter controls
2 speed travel, power boost, boom priority, arm-in regeneration, safety lock

Enhanced Operator Cab

Improved Visibility

Enlarged cab with improved visibility / See-through upper skylight for visibility and ventilation
Larger right-side glass - now one piece, for better right visibility
Safety glass windows on all sides - less expensive than (polycarbonate) and won't scratch or fade
Closeable sunshade for operator convenience / Reduced front window seam for improved operator view

Improved Cab Construction

New steel tube construction for added operator safety, protection and durability
New window open/close mechanism designed with cable and spring lift assist and single latch release

Improved Suspension Seat / Console Assembly

Ergonomic joysticks with auxiliary control buttons for attachment use. Now with new sleek styling
Adjustable heated suspension seat, control console and arm rests

Advanced 7" Color Cluster

New Color LCD Display with easy-to-read digital gauges for hydraulic oil temperature, water temperature, and fuel. A simplified design makes adjustment and diagnostics easier. Also, new enhanced features such as rear-view camera are integrated into monitor.
3 power modes : (P) Power, (S) Standard, (E) Economy, 2 work modes : Dig & Attachment, (U) User mode for operator preference
Enhanced self-diagnostic features with GPS download capability
One pump flow or two pump flow for optional attachment now selectable through the cluster / New anti-theft system with password capability
Boom speed and arm regeneration are selectable through the monitor.
Auto power boost is now available - selectable (on/off) through the monitor.
Powerful air conditioning and heat with auto climate control, 20% more heat and air output than 7A series!
RMS (Remote Management System) works through GPS/satellite technology to ultimately provide better customer service and support.

Preference

Operating the R145CR-9 is unique to every operator. Operators can fully customize their work environment and operating preferences to fit their individual needs.



*Photo may include optional equipment.



Wide Cabin with Excellent Visibility

The newly designed cabin was conceived for more space, a wider field of view and operator comfort. Special attention was given to a clear, open and convenient interior with plenty of visibility on the machine surroundings and the job at hand. This well balanced combination of precision aspects put the operator in the perfect position to work safely and securely.

Operator Comfort

In the 9 series cabin you can easily adjust the seat, console and armrest settings to best suit your personal operating preferences. Seat and console position can be set together and independent from each other. Additional creature comforts include the fully automatic high-capacity airconditioning system and the CD/MP3 radio.



Reduced Stress

Work is stressful enough. Your work environment should be stress free. Hyundai's 9 series provides improved cab amenities, additional space and a comfortable seat to minimize stress to the operator. A powerful climate control system provides the operator with optimum air temperature. An advanced audio system with CD player, AM/FM stereo and MP3 capabilities, plus remotely located controls is perfect for listening to music favorites. Operators can even talk on the phone with the hands-free cell phone feature.



Operator - Friendly Cluster

The advanced new cluster with 7 inch wide color LCD screen and toggle switch allows the operator to select his personal machine preferences. Power and work mode selection, self diagnostics, optional rear-view camera, maintenance check lists, start-up machine security, and video functions were integrated into the cluster to make the machine more versatile and the operator more productive.



Precision

Innovative hydraulic system technologies make the 9 series excavator fast, smooth and easy to control.



*Photo may include optional equipment.

Computer Aided Power

The engine horsepower and hydraulic horsepower together in unison through the advanced CAPO(Computer Aided Power Optimization) system, provide the precise flow needed for the job at hand. Operators can set their own preferences for boom or swing priority, power mode selection and optional work tools at the touch of a button. The CAPO system also provides complete self diagnostic features and digital gauges for important information like hydraulic oil temperature, water temperature and fuel level. This system interfaces with multiple sensors placed throughout the hydraulic system as well as the electronically controlled engine to provide the optimum level of engine power and hydraulic flow.

Power Mode

P (Power Max) mode maximizes machine speed and power for mass production. S (Standard) mode provides a reduced, fixed rpm for optimum performance and improved fuel economy. For maximum fuel savings and improved control, E (Economy) mode provides precise flow and engine power based on load demand. Three unique power modes provide the operator with custom power, speed and fuel economy.

Work Mode

The work mode allows the operator to select single flow attachments like a hydraulic breaker or bi-directional flow attachments like a crusher. Flow settings unique to each attachment can be programmed from within the cluster.

User Mode

Some jobs require more precise machine settings. Using the versatile U (User) mode, the operator can customize engine speed, pump output, idle speed and other machine settings for the job at hand.

Improved Hydraulic System



To achieve optimum precision, Hyundai redesigned the hydraulic system to provide the operator with super fine touch and improved controllability. Improved pump flow control reduces flow when controls are not being used to minimize fuel consumption.

Improved spool valves in the control valve are engineered to provide more precise flow to each function with less effort.

Improved hydraulic valves, precision-designed variable volume piston pumps, fine-touch pilot controls, and enhanced travel functions make any operator running a 9 series look like a smooth operator. Newly improved features

include arm-in and boom-down flow regeneration, improved control valve technology and innovative auto boom and swing priority for optimal performance in any application.



Auto Boom & Swing Priority

This smart function automatically and continuously looks the ideal hydraulic flow balance for the boom and swing motions of the machine. The advanced CAPO system monitors the hydraulic system and adjusts its settings to maximize performance and productivity.

Performance

9 series is designed for maximum performance to keep the operator working productively.

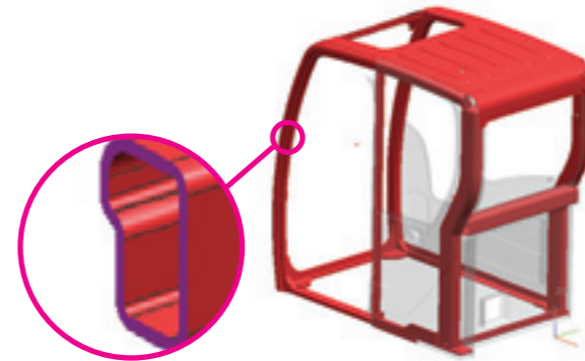

*Photo may include optional equipment.

Track Rail Guard & Adjusters

adjustment is made easy with standard grease cylinder track adjusters and shock absorbing springs.

Durable track rail guards keep track links in place. Track



Structure Strength

The 9 series cabin structure has been fitted with stronger but slimmer tubing for more safety and improved visibility. Low-stress, high strength steel is integrally welded to form a stronger, more durable upper and lower frame. Structural integrity was tested by way of FEM (Finite Elements Method) analysis and long-term durability tests.

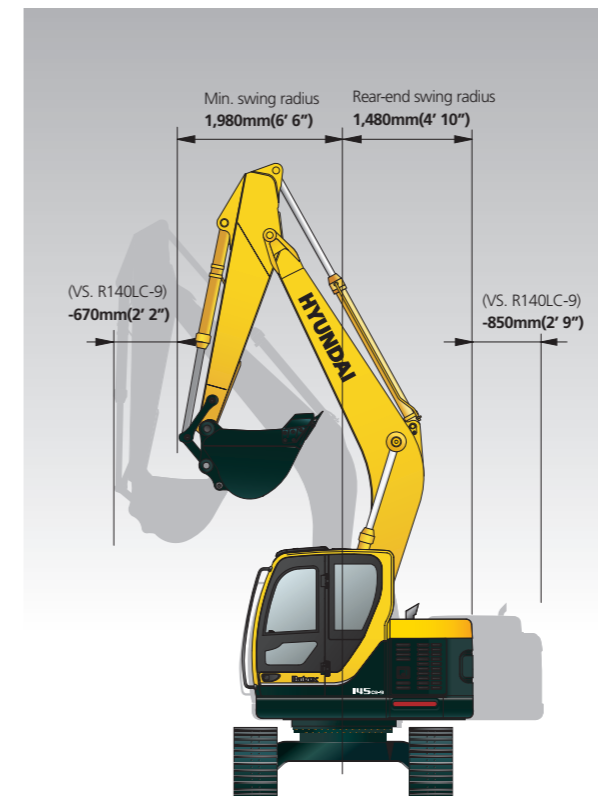

Excellent Performance in Confined Areas

R145CR-9's short (1,480mm) tail swing radius allows the operator work in confined areas like close to buildings on roadways, and in urban areas. This Compact radius design provides easy and efficient operation in any limited space work environment.

Mitsubishi D04FD-TAA

The Tier III, four cylinder, 4 cycle, turbo-charged, charge air cooled, Mitsubishi D04FD-TAA engine provides maximum power, reliability, optimum fuel economy, and reduced emissions. Electronically controlled fuel injection and diagnostic capabilities add to the engines efficiency and serviceability.

Heavy-duty strength

Everyone who's ever worked on construction equipment knows, there is no substitute for power and durability. The D04FD-TAA handles the toughest loads and the roughest work conditions.

At the same time, it delivers better fuel economy, has better cold starting capability and is up to 50% quieter in operation. Plus, the heavy-duty design of the D04FD-TAA engine block and components add reliability and durability you can count on every day, year after year.

Both fuel-efficiency and response are significantly enhanced with the Mitsubishi high pressure common rail fuel system. The system delivers high pressure injection, independent of engine speed, for optimum performance and flexibility at every rpm.

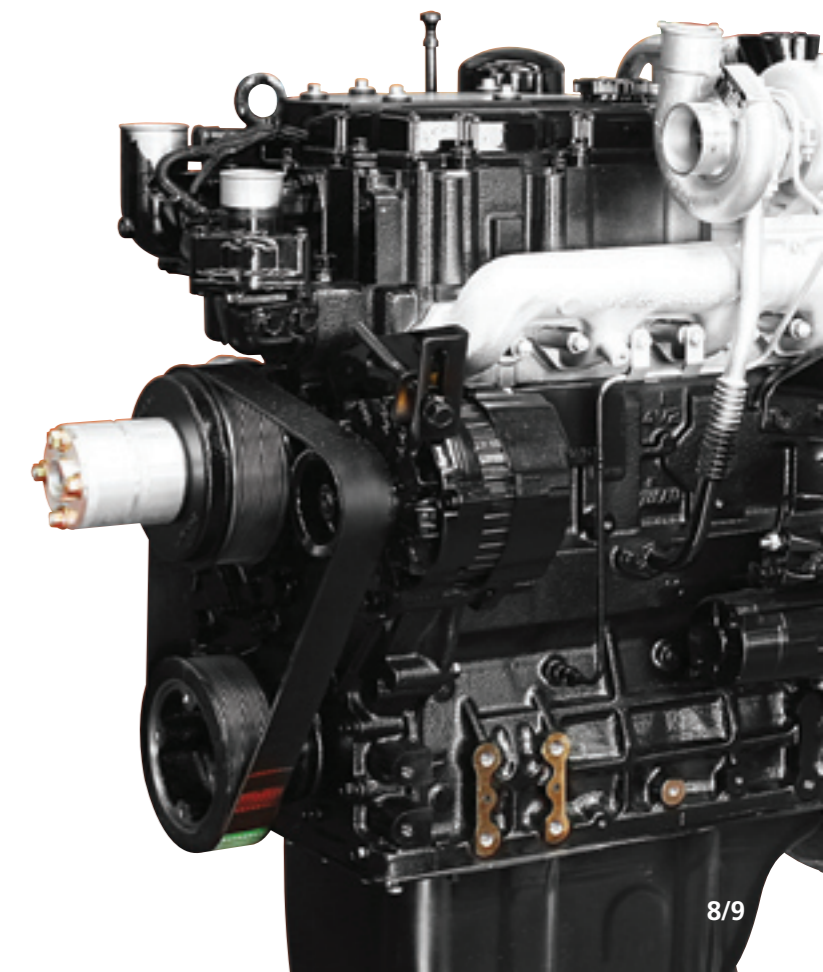

Profitable

9 series is designed to maximize profitability through improved efficiencies, enhanced service features and longer life components.



*Photo may include optional equipment.

Fuel Efficient

9 series excavators are engineered to be extremely fuel efficient. New innovations like two-stage auto decel system and the new economy mode help to conserve fuel and reduce the impact on the environment.



Hi-mate (Remote Management System)

Hi-mate, Hyundai's proprietary remote management system, provides operators and dealer service personnel access to vital service and diagnostic information on the machine from any computer with internet access. Users can pinpoint machine location using digital mapping and set machine work boundaries, reducing the need for multiple service calls. Hi-mate saves time and money for the owner and dealer by promoting preventative maintenance and reducing machine downtime.



Easy Access

Ground-line access to filters, lube fittings, fuses, machine computer components and wide open compartments makes service more convenient on the 9 series.

Extended Life Components

9 series excavators were designed with bushings designed for extended lube intervals (250 hrs) & ultra high molecular weight polymer shims (wear resistant, noise reducing), extended-life hydraulic filters (1,000hrs), long-life hydraulic oil (5,000hrs), more efficient cooling systems and integrated preheating systems which extend service intervals, minimize operating costs and reduce machine down time.

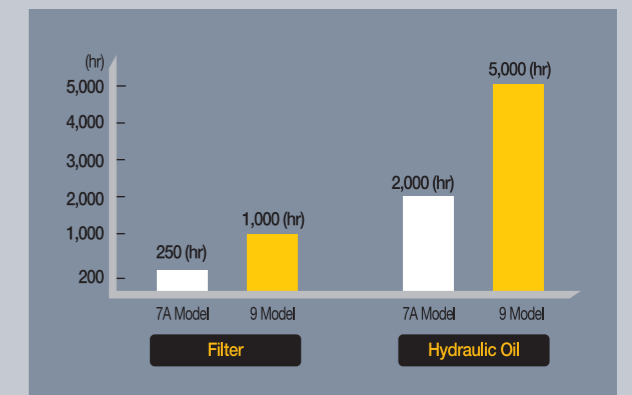
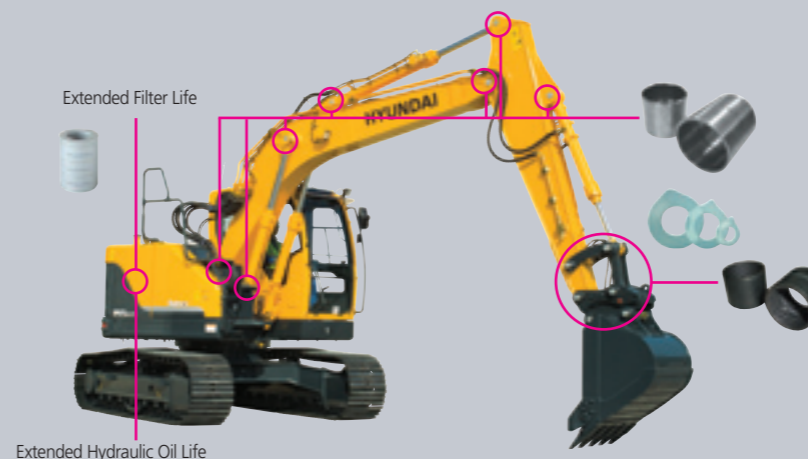

Specifications

ENGINE

MODEL	Mitsubishi D04FD-TAA		
Type	Water cooled, 4 cycle Diesel, 4-cylinders in line, direct injection, turbocharged charger and air cooled		
Rated flywheel horse power	SAE	J1995 (gross) J1349 (net)	119 HP (89 kW)/ 2,000 rpm 113 HP (85 kW)/ 2,000 rpm
	DIN	6271/1 (gross) 6271/1 (net)	121 PS (89 kW)/ 2,000 rpm 115 PS (85 kW)/ 2,000 rpm
Max. torque	45.4 kgf-m(328 lbf-ft)/ 1,700 rpm		
Bore X stroke	102 x 130 mm (4.0" x 5.1")		
Piston	4,250cc (260 in³)		
Batteries	2 X 12V X 80AH		
Starting motor	24V- 5.0kW		
Alternator	24V- 50Amp		

HYDRAULIC SYSTEM

MAIN PUMP	
Type	Variable displacement tandem axis piston pumps
Rated flow	2 X 130L /min (34.3 US gpm / 28.6 UK gpm)
Sub-pump for pilot circuit	Gear pump

Cross-sensing and fuel saving pump system.

HYDRAULIC MOTORS

Travel	Two speed axial pistons motor with brake valve and parking brake
Swing	Axial piston motor with automatic brake

RELIEF VALVE SETTING

Implement circuits	350 kgf/cm² (4,980 psi)
Travel	350 kgf/cm² (4,980 psi)
Power boost (boom, arm, bucket)	380 kgf/cm² (5,410 psi)
Swing circuit	285 kgf/cm² (4,050 psi)
Pilot circuit	40 kgf/cm² (570 psi)
Service valve	Installed

HYDRAULIC CYLINDERS

No. of cylinder bore X stroke	Boom: 105 X 1,105 mm (4.1" X 43.5")
	Arm: 115 X 1,138 mm (4.5" X 44.8")
	Bucket: 100 X 840 mm (3.9" X 33.1")
	Blade: 100 X 260 mm (3.9" X 10.2")

DRIVES & BRAKES

Drive method	Fully hydrostatic type
Drive motor	Axial piston motor, in-shoe design
Reduction system	Planetary reduction gear
Max. drawbar pull	13,300 kgf (29,321 lbf)
Max. travel speed(high) / (low)	5.5 km/hr (3.4 mph) / 3.2 km/hr (2.0 mph)
Gradeability	30° (58 %)
Parking brake	Multi wet disc

CONTROL

Pilot pressure operated joysticks and pedals with detachable lever provide almost effortless and fatigueless operation.

Pilot control	Two joysticks with one safety lever (LH): Swing and arm, (RH): Boom and bucket(ISO)
Traveling and steering	Two levers with pedals
Engine throttle	Electric, Dial type

SWING SYSTEM

Swing motor	Fixed displacement axial piston motor
Swing reduction	Planetary gear reduction
Swing bearing lubrication	Grease-bathed
Swing brake	Multi wet disc
Swing speed	12 rpm

COOLANT & LUBRICANT CAPACITY

Refilling	liter	US gal	UK gal
Fuel tank	232	61.3	51.0
Engine coolant	14.5	3.8	3.2
Engine oil	17.5	4.6	3.8
Swing device-gear oil	2.5	0.7	0.5
Final drive(each)-gear oil	3.6	1.0	0.8
Hydraulic system(including tank)	180	47.6	39.6
Hydraulic tank	96	25.4	21.1

UNDERCARRIAGE

The X-leg type center frame is integrally welded with reinforced box-section track frames. The undercarriage includes lubricated rollers, idlers, track adjusters with shock absorbing springs and sprockets, and a track chain with double or triple grouser shoes.

Center frame	X - leg type			
Track frame	Pentagonal box type			
No. of shoes on each side		45EA		47EA
No. of carrier roller on each side	R145CR-9	1 EA	R145LCR-9	2 EA
No. of track roller on each side		7 EA		7 EA
No. of rail guard on each side		2 EA		2 EA

OPERATING WEIGHT (APPROXIMATE)

Operating weight, including 4,600mm (15' 1") boom, 2,500mm (8' 2") arm, SAE heaped 0.52m³ (0.68 yd³) bucket, lubricant, coolant, full fuel tank, full hydraulic tank, and all standard equipments.

MAJOR COMPONENT WEIGHT

Upperstructure	6,950 kg (15,320 lb)
Counterweight	2,800 kg (6,170 lb)
4.6m (15' 1") mono boom(with arm cylinder)	1,030 kg (2,270 lb)

OPERATING WEIGHT

Shoes		Operating weight	Ground pressure	
Type	Width mm(in)	kg(lb)	kgf/cm² (psi)	
Triple grouser	500 (20")	R145CR-9	14,600(32,190)	0.46(6.54)
		R145CR-9 (Dozer type)	15,400(33,950)	0.49(6.97)
		R145LCR-9	14,785(32,600)	0.47(6.68)
		R145LCR-9 (Dozer type)	15,585(34,360)	0.49(6.97)
	600 (24")	R145CR-9	14,790(32,610)	0.39(5.55)
		R145CR-9 (Dozer type)	15,610(34,410)	0.41(5.83)
		R145LCR-9	14,980(33,020)	0.40(5.69)
		R145LCR-9 (Dozer type)	15,800(34,830)	0.42(5.97)
	700 (28")	R145CR-9	15,020(33,110)	0.34(4.83)
		R145CR-9 (Dozer type)	15,840(34,920)	0.36(5.12)
		R145LCR-9	15,215(33,540)	0.34(4.83)
		R145LCR-9 (Dozer type)	16,035(35,350)	0.36(5.12)

BUCKETS

All buckets are welded with high-strength steel.

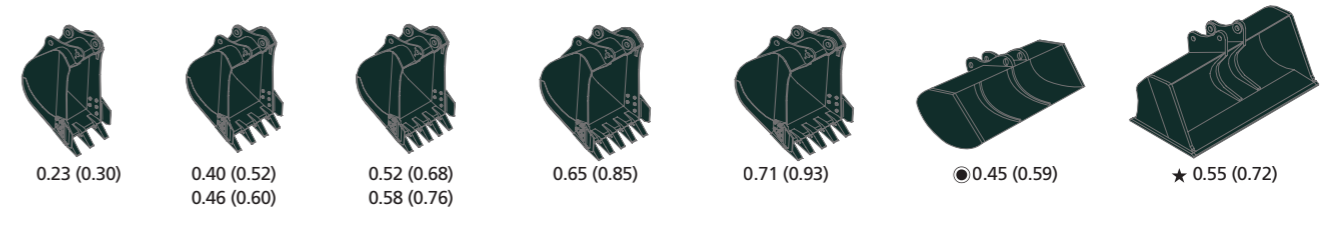

Capacity m³ (yd³)	Width mm (in)	Weight kg (lb)	Recommendation mm (ft-in)					
			4,600 (15' 1") Boom					
			1,900 (6' 3") Arm	2,100 (6' 11") Arm	2,500 (8' 2") Arm	3,000 (9' 10") Arm		
0.23 (0.30)	0.20(0.26)	520(20.5)	620(24.4)	335(740)	●	●	●	■
0.40 (0.52)	0.35(0.46)	760(29.9)	860(33.9)	410(900)	●	●	●	■
0.46 (0.60)	0.40(0.52)	850(33.5)	950(37.4)	435(960)	●	●	●	▲
0.52 (0.68)	0.45(0.59)	935(36.8)	1,035(40.8)	460(1,010)	●	●	●	-
0.58 (0.76)	0.50(0.65)	1,030(40.6)	1,130(44.5)	480(1,060)	●	●	■	-
0.65 (0.85)	0.55(0.72)	1,110(43.7)	1,210(47.6)	500(1,100)	■	■	▲	-
0.71 (0.93)	0.60(0.78)	1,205(47.4)	-	540(1,190)	▲	▲	-	-
● 0.45 (0.59)	0.40(0.52)	1,520(59.8)	-	410(900)	●	●	■	-
★ 0.55 (0.72)	0.45(0.59)	1,800(70.9)	-	585(1,290)	■	▲	▲	-

● Ditching bucket

★ Slope finishing bucket

● : Applicable for materials with density of 2,000 kg /m³ (3,370 lb/ yd³) or less

■ : Applicable for materials with density of 1,600 kg /m³ (2,700 lb/ yd³) or less

▲ : Applicable for materials with density of 1,100 kg /m³ (1,850 lb/ yd³) or less

ATTACHMENT

Booms and arms are welded, a low-stress, full-box section design. 4.6m(15' 1") boom and 1.9m(6' 3"), 2.1m(6' 11"), 2.5m(8' 2"), 3.0m(9' 10") arms are available.

DIGGING FORCE

Boom	Length	mm (ft-in)	4,600 (15' 1")				Remarks
			1,030 (2,270)				
Arm	Length	mm (ft-in)	1,900 (6' 3")	2,100 (6' 11")	2,500 (8' 2")	3,000 (9' 10")	
			Weight	kg (lb)	560 (1,230)	580 (1,280)	610 (1,340)
Bucket digging force	SAE	kN	87.3[94.8]	87.3[94.8]	87.3[94.8]	87.3[94.8]	[]: Power Boost
		kgf	8,900[9,660]	8,900[9,660]	8,900[9,660]	8,900[9,660]	
		lbf	19,620[21,300]	19,620[21,300]	19,620[21,300]	19,620[21,300]	
		kN	102[110.8]	102[110.8]	102[110.8]	102[110.8]	
Arm crowd force	SAE	kN	76.5[83.1]	73.6[79.9]	62.8[68.2]	55.9[60.7]	
		kgf	7,800[8,470]	7,500[8,140]	6,400[6,950]	5,700[6,190]	
		lbf	17,200[18,670]	16,530[17,950]	14,110[15,320]	12,570[13,640]	
		kN	80.4[87.3]	77.5[84.1]	65.7[71.4]	57.9[62.8]	
Triple grouser	ISO	kgf	8,200[8,900]	7,900[8,580]	6,700[7,270]	5,900[6,410]	
		lbf	18,080[19,630]	17,420[18,910]	14,770[16,040]	13,010[14,120]	

Note: Boom weight includes arm cylinder, piping, and pin

Arm weight includes bucket cylinder, linkage, and pin

Dimensions & Working Range

R145CR-9 DIMENSIONS

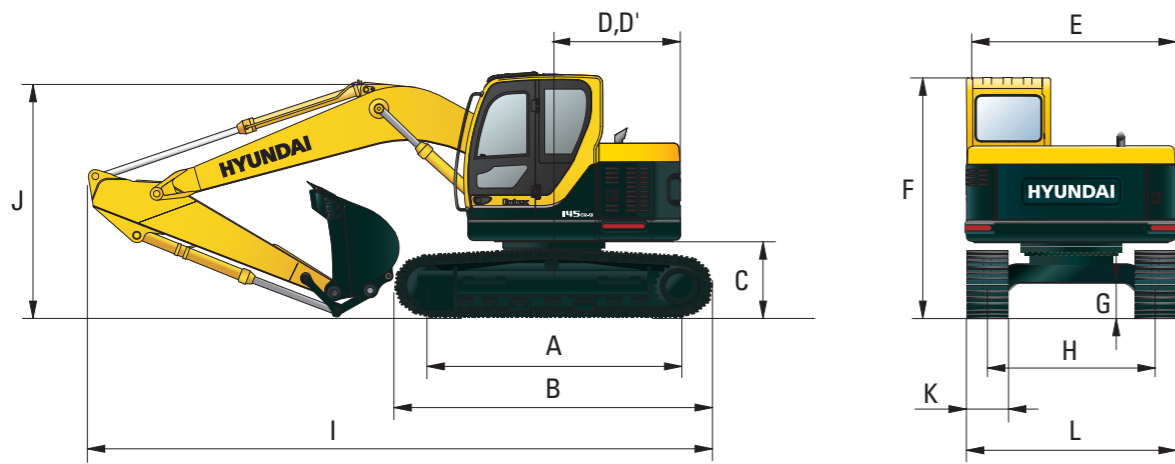

mm (ft-in)

A Tumbler distance	2,910 (9' 7")	Boom length	4,600(15' 1")			
B Overall length of crawler	3,640 (11' 11")	Arm length	1,900 (6' 3")	2,100 (6' 11")	2,500 (8' 2")	3,000 (9' 10")
C Ground clearance of counterweight	930 (3' 1")	I Overall length	7,290 (23' 11")	7,310 (23' 12")	7,270 (23' 10")	7,210 (23' 8")
D Tail swing radius	1,480 (4' 10")	J Overall height of boom	2,630 (8' 8")	2,710 (8' 11")	2,860 (9' 5")	3,210 (10' 6")
D' Rear-end length	1,480 (4' 10")	K Track shoe width	500 (20")	600 (24")	700 (28")	
E Overall width of upperstructure	2,500 (8' 2")	L Overall width	2,500 (8' 2")	2,600 (8' 6")	2,700 (8' 10")	
F Overall height of cab	2,900 (9' 6")					
G Min. ground clearance	440 (1' 5")					
H Track gauge	2,000 (6' 7")					

Dimensions & Working Range

R145LCR-9 DIMENSIONS

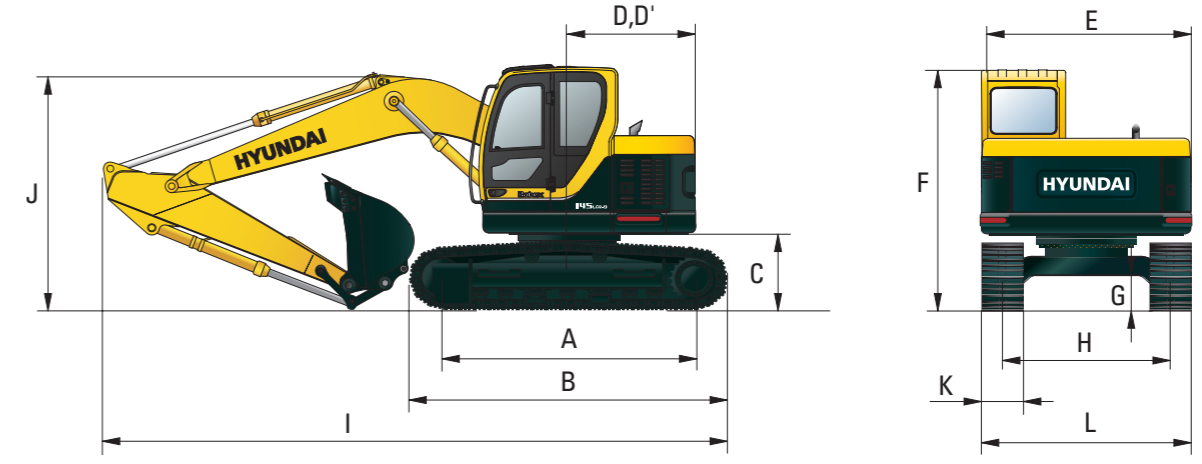

mm (ft-in)

A Tumbler distance	3,090 (10' 2")	Boom length	4,600(15' 1")			
B Overall length of crawler	3,820 (12' 6")	Arm length	1,900 (6' 3")	2,100 (6' 11")	2,500 (8' 2")	3,000 (9' 10")
C Ground clearance of counterweight	930 (3' 1")	I Overall length	7,380 (24' 3")	7,400 (24' 3")	7,360 (24' 2")	7,300 (23' 11")
D Tail swing radius	1,480 (4' 10")	J Overall height of boom	2,630 (8' 8")	2,710 (8' 11")	2,860 (9' 5")	3,210 (10' 6")
D' Rear-end length	1,480 (4' 10")	K Track shoe width	500 (20")	600 (24")	700 (28")	
E Overall width of upperstructure	2,500 (8' 2")	L Overall width	2,500 (8' 2")	2,600 (8' 6")	2,700 (8' 10")	
F Overall height of cab	2,900 (9' 6")					
G Min. ground clearance	440 (1' 5")					
H Track gauge	2,000 (6' 7")					

R145CR-9 WORKING RANGE

mm (ft-in)

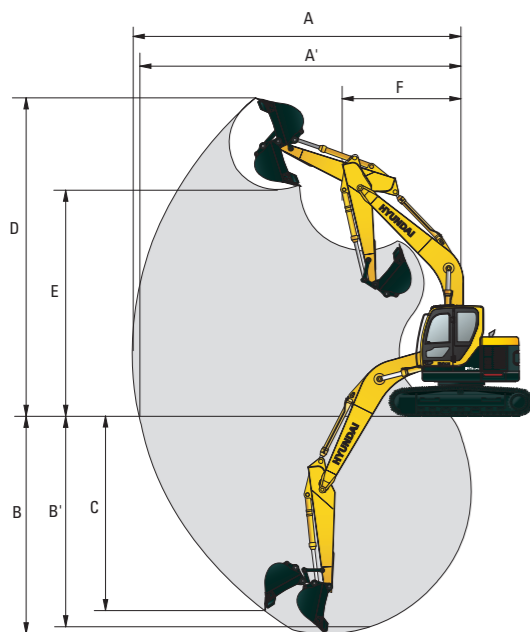

Boom length	4,600(15' 1")			
Arm length	1,900 (6' 3")	2,100 (6' 11")	2,500 (8' 2")	3,000 (9' 10")
A Max. digging reach	7,730 (25' 4")	7,900 (25' 11")	8,310 (27' 3")	8,770 (28' 9")
A' Max. digging reach on ground	7,580 (24' 10")	7,750 (25' 0")	8,170 (26' 10")	8,630 (28' 4")
B Max. digging depth	4,890 (16' 1")	5,100 (16' 9")	5,500 (18' 1")	5,990 (19' 8")
B' Max. digging depth (8' level)	4,640 (15' 3")	4,870 (16' 0")	5,290 (17' 4")	5,810 (19' 1")
C Max. vertical wall digging depth	4,400 (14' 5")	4,600 (15' 1")	5,000 (16' 5")	5,400 (17' 9")
D Max. digging height	8,840 (29' 0")	8,970 (29' 5")	9,350 (30' 8")	9,730 (31' 11")
E Max. dumping height	6,350 (20' 10")	6,470 (21' 3")	6,850 (22' 6")	7,230 (23' 9")
F Min. swing radius	1,860 (6' 1")	2,030 (6' 8")	1,980 (6' 6")	2,260 (7' 5")

R145LCR-9 WORKING RANGE

mm (ft-in)

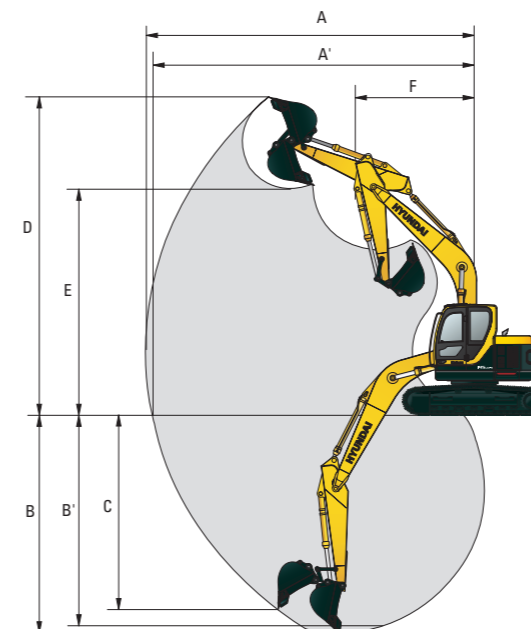

Boom length	4,600(15' 1")			
Arm length	1,900 (6' 3")	2,100 (6' 11")	2,500 (8' 2")	3,000 (9' 10")
A Max. digging reach	7,730 (25' 4")	7,900 (25' 11")	8,310 (27' 3")	8,770 (28' 9")
A' Max. digging reach on ground	7,580 (24' 10")	7,750 (25' 0")	8,170 (26' 10")	8,630 (28' 4")
B Max. digging depth	4,890 (16' 1")	5,100 (16' 9")	5,500 (18' 1")	5,990 (19' 8")
B' Max. digging depth (8' level)	4,640 (15' 3")	4,870 (16' 0")	5,290 (17' 4")	5,810 (19' 1")
C Max. vertical wall digging depth	4,400 (14' 5")	4,600 (15' 1")	5,000 (16' 5")	5,400 (17' 9")
D Max. digging height	8,840 (29' 0")	8,970 (29' 5")	9,350 (30' 8")	9,730 (31' 11")
E Max. dumping height	6,350 (20' 10")	6,470 (21' 3")	6,850 (22' 6")	7,230 (23' 9")
F Min. swing radius	1,860 (6' 1")	2,030 (6' 8")	1,980 (6' 6")	2,260 (7' 5")

Dimensions & Working Range

R145CR-9 (DOZER TYPE) DIMENSIONS

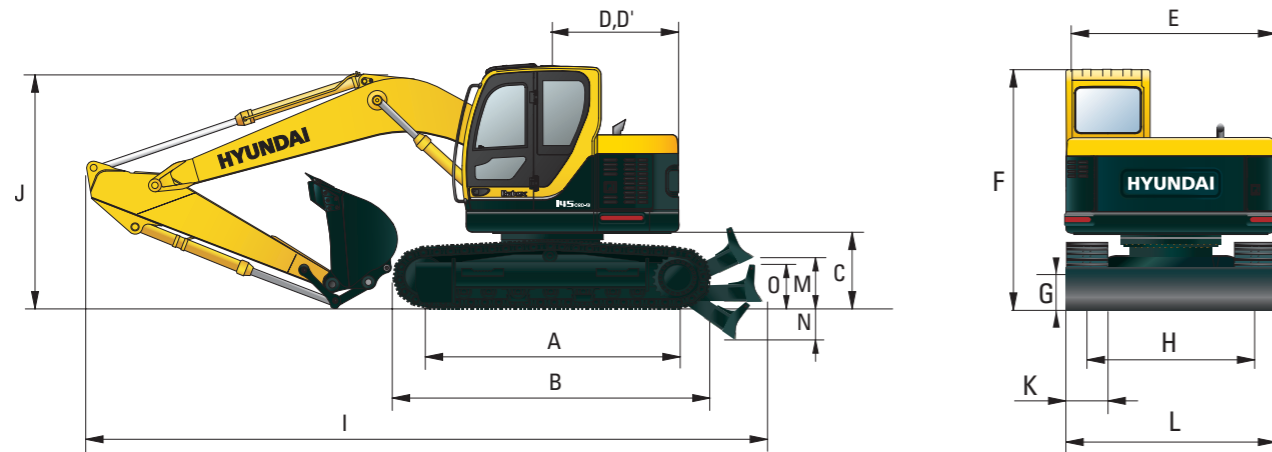

mm (ft-in)

A Tumbler distance	2,910 (9' 7")	Boom length	4,600(15' 1")			
B Overall length of crawler	3,640 (11' 11")	Arm length	1,900 (6' 3")	2,100 (6' 11")	2,500 (8' 2")	3,000 (9' 10")
C Ground clearance of counterweight	930 (3' 1")	I Overall length	7,840 (25' 9")	7,860 (25' 9")	7,820 (25' 8")	7,760 (25' 6")
D Tail swing radius	1,480 (4' 10")	J Overall height of boom	2,630 (8' 8")	2,710 (8' 11")	2,860 (9' 5")	3,210 (10' 6")
D' Rear-end length	1,480 (4' 10")	K Track shoe width	500 (20")	600 (24")	700 (28")	
E Overall width of upperstructure	2,500 (8' 2")	L Overall width	2,500 (8' 2")	2,600 (8' 6")	2,700 (8' 10")	
F Overall height of cab	2,900 (9' 6")					
G Min. ground clearance	440 (1' 5")					
H Track gauge	2,000 (6' 7")					
M Ground clearance of blade up	420 (1' 8")					
N Depth of blade down	430 (1' 6")					
O Height of blade	575 (1' 8")					

R145CR-9 (DOZER TYPE) WORKING RANGE

mm (ft-in)

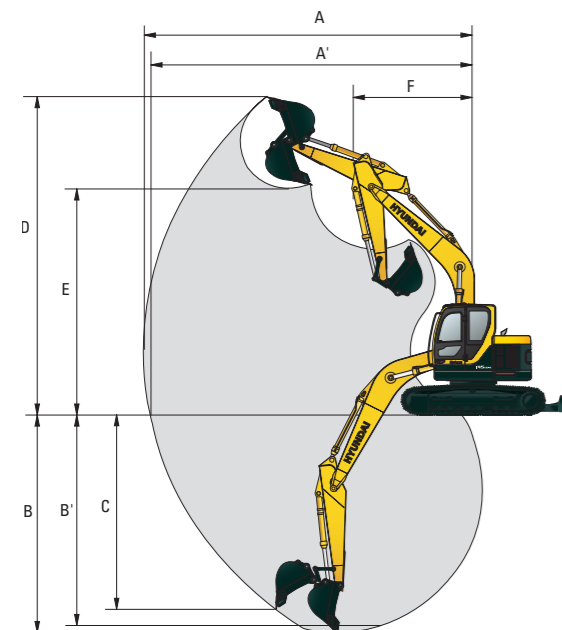

Boom length	4,600(15' 1")			
Arm length	1,900 (6' 3")	2,100 (6' 11")	2,500 (8' 2")	3,000 (9' 10")
A Max. digging reach	7,730 (25' 4")	7,900 (25' 11")	8,310 (27' 3")	8,770 (28' 9")
A' Max. digging reach on ground	7,580 (24' 10")	7,750 (25' 0")	8,170 (26' 10")	8,630 (28' 4")
B Max. digging depth	4,890 (16' 1")	5,100 (16' 9")	5,500 (18' 1")	5,990 (19' 8")
B' Max. digging depth (8' level)	4,640 (15' 3")	4,870 (16' 0")	5,290 (17' 4")	5,810 (19' 1")
C Max. vertical wall digging depth	4,400 (14' 5")	4,600 (15' 1")	5,000 (16' 5")	5,400 (17' 9")
D Max. digging height	8,840 (29' 0")	8,970 (29' 5")	9,350 (30' 8")	9,730 (31' 11")
E Max. dumping height	6,350 (20' 10")	6,470 (21' 3")	6,850 (22' 6")	7,230 (23' 9")
F Min. swing radius	1,860 (6' 1")	2,030 (6' 8")	1,980 (6' 6")	2,260 (7' 5")

Dimensions & Working Range

R145LCR-9 (DOZER TYPE) DIMENSIONS

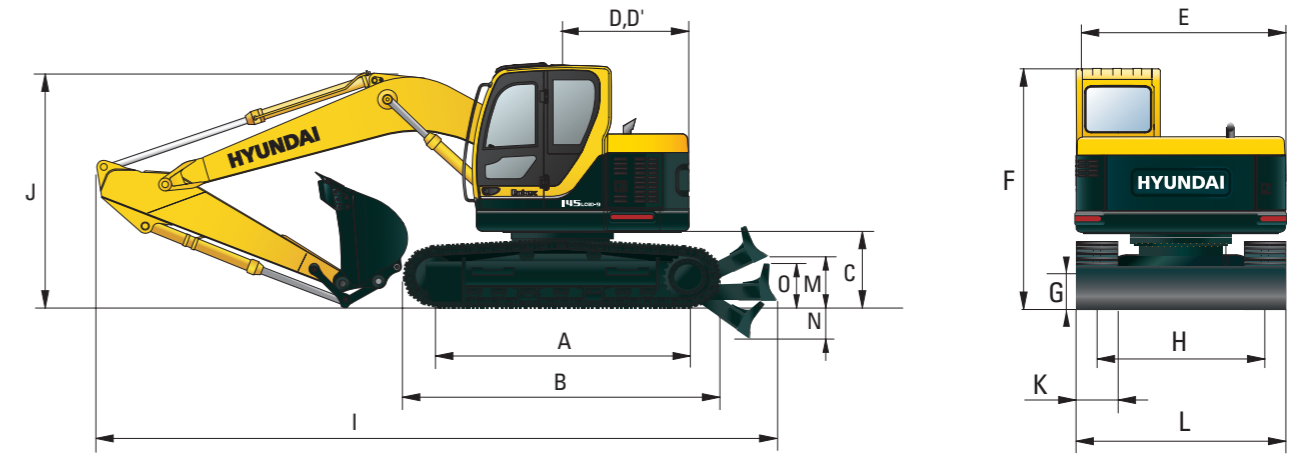

mm (ft-in)

A Tumbler distance	3,090 (10' 2")	Boom length	4,600(15' 1")			
B Overall length of crawler	3,820 (12' 6")	Arm length	1,900 (6' 3")	2,100 (6' 11")	2,500 (8' 2")	3,000 (9' 10")
C Ground clearance of counterweight	930 (3' 1")	I Overall length	7,840 (25' 9")	7,860 (25' 9")	7,820 (25' 8")	7,760 (25' 6")
D Tail swing radius	1,480 (4' 10")	J Overall height of boom	2,630 (8' 8")	2,710 (8' 11")	2,860 (9' 5")	3,210 (10' 6")
D' Rear-end length	1,480 (4' 10")	K Track shoe width	500 (20")	600 (24")	700 (28")	
E Overall width of upperstructure	2,500 (8' 2")	L Overall width	2,500 (8' 2")	2,600 (8' 6")	2,700 (8' 10")	
F Overall height of cab	2,900 (9' 6")					
G Min. ground clearance	440 (1' 5")					
H Track gauge	2,000 (6' 7")					
M Ground clearance of blade up	420 (1' 8")					
N Depth of blade down	430 (1' 6")					
O Height of blade	575 (1' 8")					

R145LCR-9 (DOZER TYPE) WORKING RANGE

mm (ft-in)

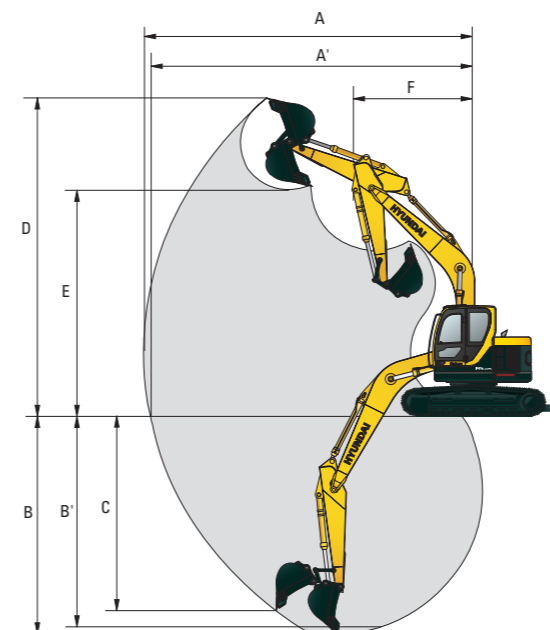

Boom length	4,600(15' 1")			
Arm length	1,900 (6' 3")	2,100 (6' 11")	2,500 (8' 2")	3,000 (9' 10")
A Max. digging reach	7,730 (25' 4")	7,900 (25' 11")	8,310 (27' 3")	8,770 (28' 9")
A' Max. digging reach on ground	7,580 (24' 10")	7,750 (25' 0")	8,170 (26' 10")	8,630 (28' 4")
B Max. digging depth	4,890 (16' 1")	5,100 (16' 9")	5,500 (18' 1")	5,990 (19' 8")
B' Max. digging depth (8' level)	4,640 (15' 3")	4,870 (16' 0")	5,290 (17' 4")	5,810 (19' 1")
C Max. vertical wall digging depth	4,400 (14' 5")	4,600 (15' 1")	5,000 (16' 5")	5,400 (17' 9")
D Max. digging height	8,840 (29' 0")	8,970 (29' 5")	9,350 (30' 8")	9,730 (31' 11")
E Max. dumping height	6,350 (20' 10")	6,470 (21' 3")	6,850 (22' 6")	7,230 (23' 9")
F Min. swing radius	1,860 (6' 1")	2,030 (6' 8")	1,980 (6' 6")	2,260 (7' 5")

