



**Bobcat**®

**S150**

Compact Loaders



## Machine Rating

Rated operating capacity	703 kg
Tipping load	1407 kg
Pump capacity	64 l/min
System relief at quick couplers	22.4 —23.1 MPa
Max. travel speed (low range)	11.8 km/h
Max. travel speed (high range - option)	17.9 km/h

## Engine

Make / Model	Kubota / V2203-M-DI-E2B-BC-3
Fuel / Cooling	Diesel / Liquid
Power	34.3 kW
Torque at 1700 RPM (SAE J1995 gross)	150 Nm
Number of cylinders	4
Displacement	2.194 l
Fuel tank capacity	90.8 l

## Weights

Operating weight	2632 kg
------------------	---------

## Controls

Vehicle steering	Direction and speed controlled by two hand levers
Loader hydraulics tilt and lift	Separate foot pedals or optional Advanced Control System (ACS), Advanced Hand Controls (AHC) or Selectable Joystick Controls (SJC)
Front auxiliary (standard)	Electrical switch on right-hand steering lever

## Drive System

Transmission	Infinitely variable tandem hydrostatic piston pumps, driving two fully reversing hydrostatic motors
--------------	---

## Standard Features

High-back cushion suspension seat	Instrumentation
Automatically activated glow-plugs	Lift arm support
Bob-Tach™ frame	Operating lights, front and rear
Bobcat Interlock Control System (BICS)	Parking brake
Deluxe operator cab	Seat belt
Includes interior cab foam, side, top and rear windows	Seat bar
Electrically activated proportional front auxiliary hydraulics	Spark arrestor muffler
Engine/hydraulics system shutdown	10 x 16.5, 10-ply, Heavy duty tyres
Hydraulic bucket positioning	CE certification
* Roll Over Protective Structure (ROPS) – meets requirements of SAE-J1040 and ISO 3471; Falling Object Protective Structure (FOPS) - meets requirements of SAE-J1043 and ISO 3449, Level I	

## Options

Deluxe instrument panel	10 x 16.5, 10-ply, Severe duty poly filled tyres
Power Bob-Tach™	Advanced Control System (ACS)
Cab enclosure with heat	Advanced Hand Controls (AHC)
31 x 12-16.5, Superflotation tyres	Selectable Joystick Controls (SJC)
10 x 16.5, 10-ply, Heavy duty tyres, offset rims	Two speed
10 x 16.5, 10-ply, Severe duty tyres	

## Dimensions

All dimensions in mm.

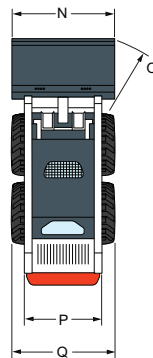
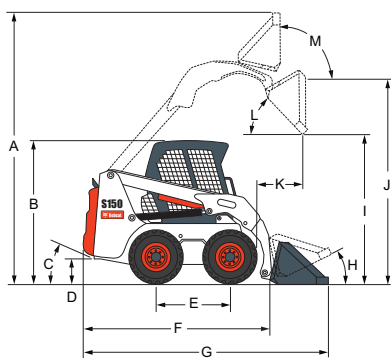

(A)	3759 mm	(J)	2908 mm
(B)	1938 mm	(K)	461 mm
(C)	23°	(L)	44°
(D)	191 mm	(M)	92°
(E)	1030 mm	(N)	1575 mm
(F)	2586 mm	(N)	1727 mm
(G)	3310 mm	(N)	1880 mm
(H)	25°	(O)	2166 mm
(I)	2197 mm	(P)	1232 mm
		(P)	1385 mm
		(P)	1328 mm
		(Q)	1524 mm
		(Q)	1676 mm
		(Q)	1829 mm

## Attachments

Angle blade	
Angle broom*†	
Auger	
Backhoe	
Box blade	
Brushcat rotary cutter	
Buckets	
Chipper*	
Combination bucket	
Concrete pump*	
Cutter crusher*	
Digger	
Dozer blade*	
Dumping hopper	
Ejector bucket	
Farm grapple	
Grader*	
Hydraulic breaker**	
Industrial grapple	
Landplane	
Landscape rake	
Pallet fork – standard	
Pallet fork – hydraulic	
Planer*	
Rear stabiliser	
Scarifier	
Snow blower*	
Sod layer*	
Soil conditioner*	
Spreader	
Stump grinder*	
Super scraper	
Sweeper	
Three-point hitch	
Tiller	
Tilt-Tatch™	
Tracks, steel	
Tree transplanter*	
Trench compactor	
Trencher	
Utility forks	
Vibratory roller	
Water kit	
Wheel saw	
Whisker broom	
*Attachment control kit required.	
**When operating the loader with this attachment, a Special Applications Kit, which includes a 12 mm Lexan front door with 6 mm top and rear windows, must be used.	
†Optional water kit.	



www.bobcat.eu